



**ZENA**<sup>™</sup> **INCORPORATED**

330 Club Springs Road  
Elmwood, Tennessee 38560  
U.S.A.

Phone: 615-897-2011  
FAX: 615-897-2023

# Instructions & Diagrams

## TS101\_UP

### Control Series



**ZENA**<sup>™</sup> **INCO**

330 Club Springs Ro:  
Elmwood, Tennessee  
U.S.A.

Phone: 615-897-2011  
FAX: 615-897-2023

ZENA<sup>™</sup> and Backpack<sup>™</sup> are trademarks owned by ZENA, Inc. for its welding systems and related products.

Protected by US Pat. 6,512,119. Other US & Foreign Patents Pending.

## The ZENA TS101\_UP Alternate Control Option is supplied with the following components:

- Model TS101 Electronic Electrode Contact Detector/Switch,
- Model PCIM Welding Power Control Module, **and/or** a TS101\_IPlug Interface adapter which enables the use of the TS101 with standard ZENA welding cables to augment the function of the built-in power control button, and/or
- Optionally** -- depending on model ordered -- a 20' Standard Welding Cable Set with 400A Tweeco Style Screw Clamp Electrode Holder and either a 300A or 600A Ground Clamp

## TS101\_UP Operation

The TS101\_UP option allows the welding system operator to use standard welding cables with the ZENA welding system.

Two modules provide this control -- a TS101 Electronic Electrode Contact Detector/Switch and a PCIM Welding Power Control Module.

With this option, welding system ON/OFF control is triggered by electrical contact, or the lack of electrical contact, between an electrode mounted in the electrode holder and the ground clamp. When electrode contact occurs the welding system is switched ON and automatic speed control circuits are

triggered

simultaneously. The

welding system's

power generator

remains on for

approximately 3

seconds to allow

the operator to

successfully

establish a welding

arc. If the welder is

equipped with a

control module that

features a time

delay speed control

circuit engine speed

will remain high for

the normal period of

time (about 20

seconds) before

engine speed

reduction occurs.

Welders with

standard control

modules will reduce

or increase engine

speed as welding

generator current

goes ON or OFF.

### Using a ZENA™ TS101 Electrode Contact Sensor Switch with a PCIM.E Power Control Module, PCIM.Pot, & OPTIONAL normally open, momentary contact switch (PCIM.FS or PCIM.PB or Other)

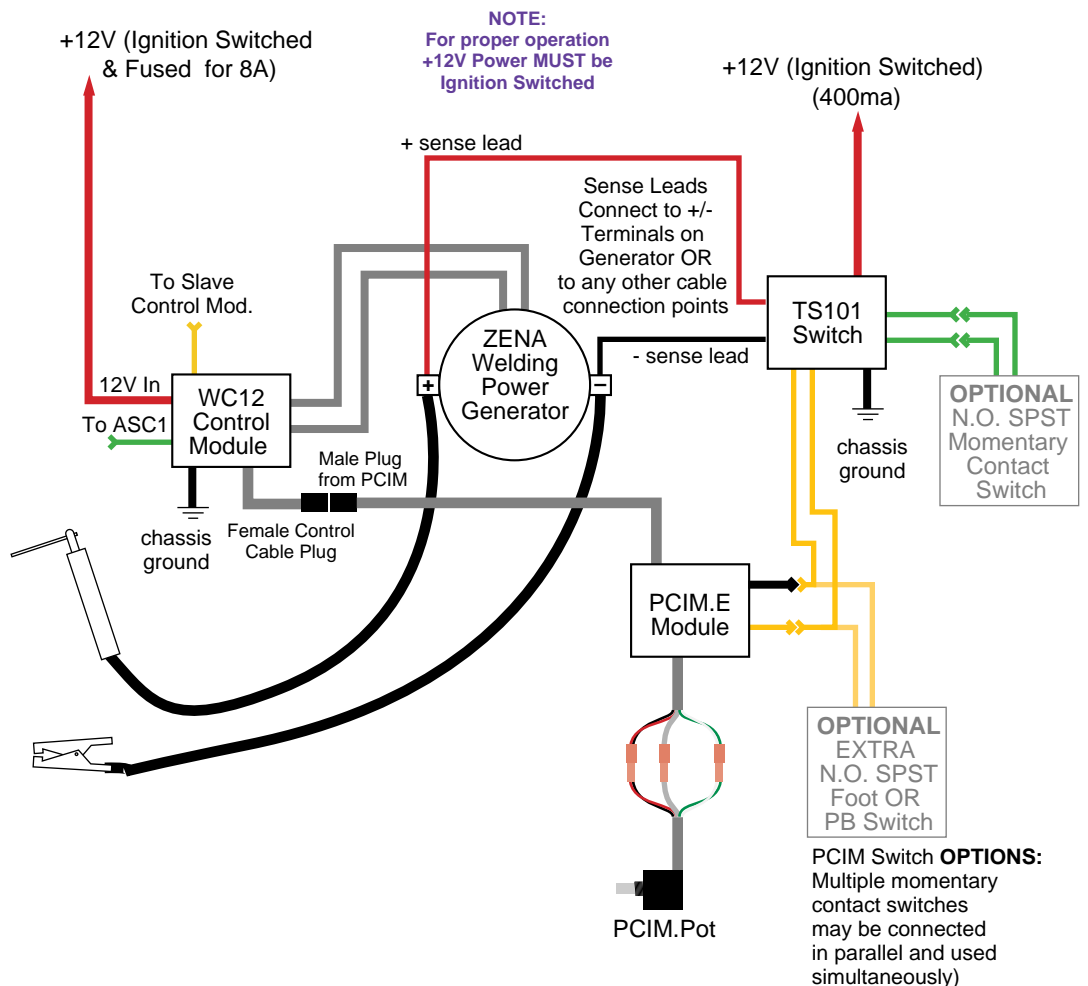

The welding system remains ON if an arc is established and remains on until the arc is “broken” by the operator. Welding current cuts off within 3 seconds of arc interruption.

Welding current is regulated by a remote waterproof potentiometer which is typically mounted near the generating unit and/or the PCIM module.

### Installation of the TS101\_UP

Installation is straightforward with the PCIM taking the place of the standard ZENA electrode holder control circuits and the TS101 providing ON/OFF switching signals to the PCIM. The TS101 connects to the PCIM just as if it were an external momentary contact single pole, single throw switch.

Interconnection of the two components with other welding system components is illustrated by the various diagrams included in this instruction set.

### TS101\_IPlug Operation

The TS101\_IPlug is an interface device which allows the TS101 to be used with the standard ZENA welding system controls. When used with these controls the TS101 will override the push button “POWER” switch on the electrode holder. The button will remain functional and can be used to start the welding system, BUT the TS101 will also turn on the welder. This means that if you accidentally touch your electrode to some object which is electrically connected to the Ground Clamp the welder will come on -- regardless the position of the push button POWER control.

### Using a ZENA™ TS101 Electrode Contact Sensor Switch with a Standard ZENA welding cable set with built-in welding controls

#### TS101\_IPlug Use

The TS101\_IPlug is placed between the welding system control module and electrode holder control cable connectors.

The two green and two yellow wires are connected to the green and yellow wires that come from the TS101.

There is no polarity for these green and yellow wire pairs. Just match the wire colors when connecting.

See the wiring diagram to the right for more information.

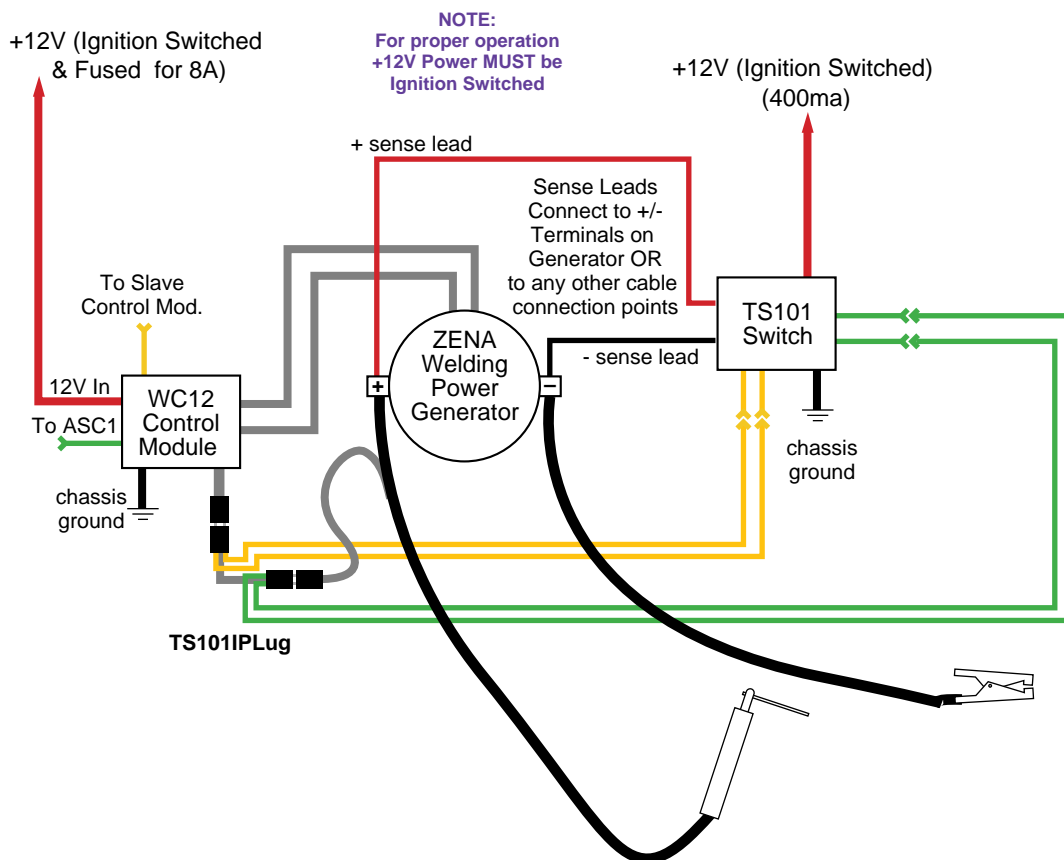

## Wiring Diagram ZENA Power Control Interface Module Model PCIM -- External Controls/Panel Mount Type (Model PCIM.E) -- Typical Hookup

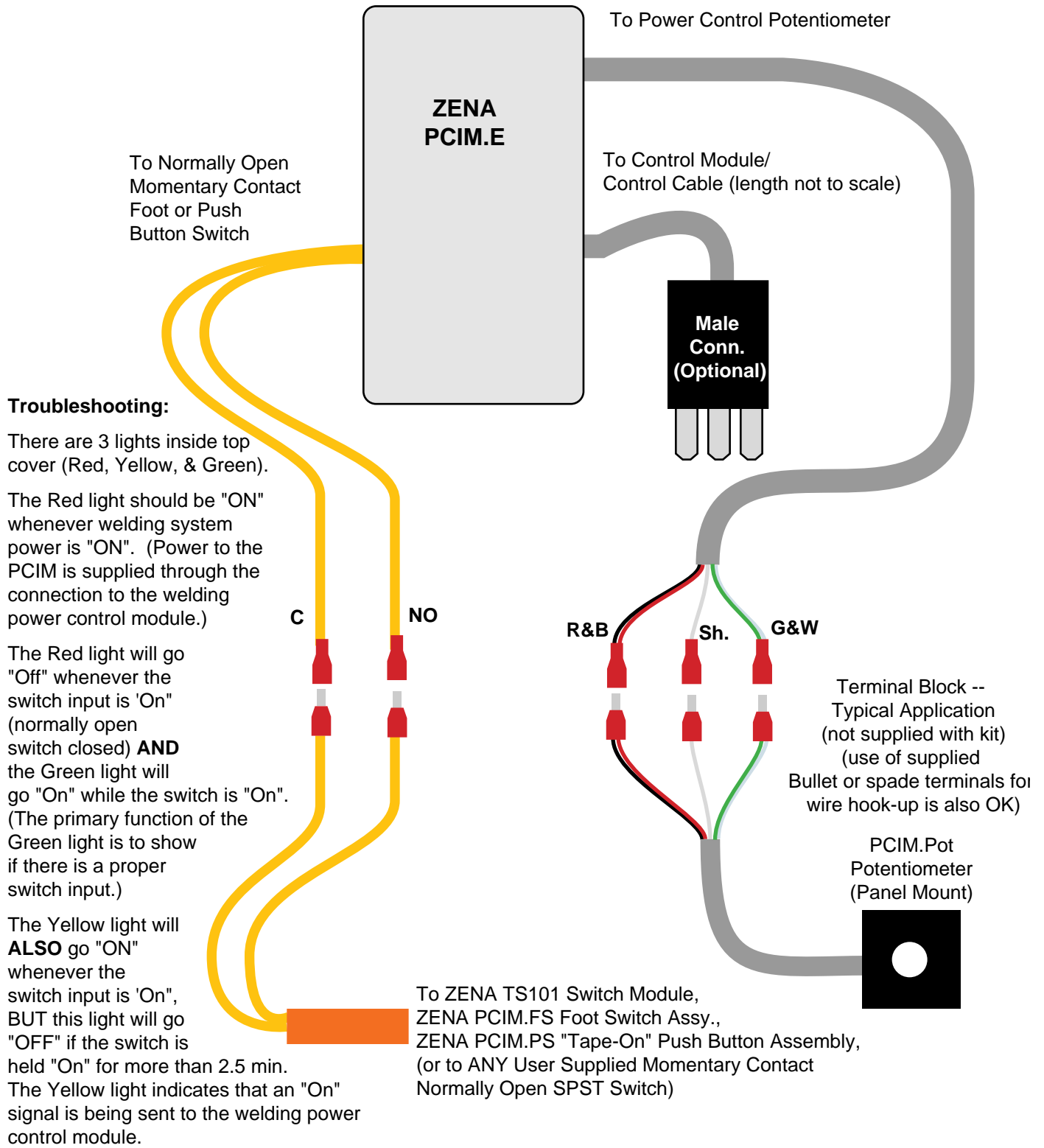

The Yellow light will also show that the safety time-out circuit which is built into the PCIM is working. Should the momentary contact switch is held on for more than 2-1/2 minutes, the PCIM will automatically switch the control signal to the power control module "Off" to prevent possible damage to the welding system. In this case, the Yellow light will be "Off" (no power on to welder), but the Green light will still be "On" (switch held on).

**Wiring Diagram ZENA Power Control Interface Module Model PCIM -- External Controls/Panel Mount Type (Model PCIM.E) -- Typical Hookup using a terminal block instead of supplied bullet connectors.**

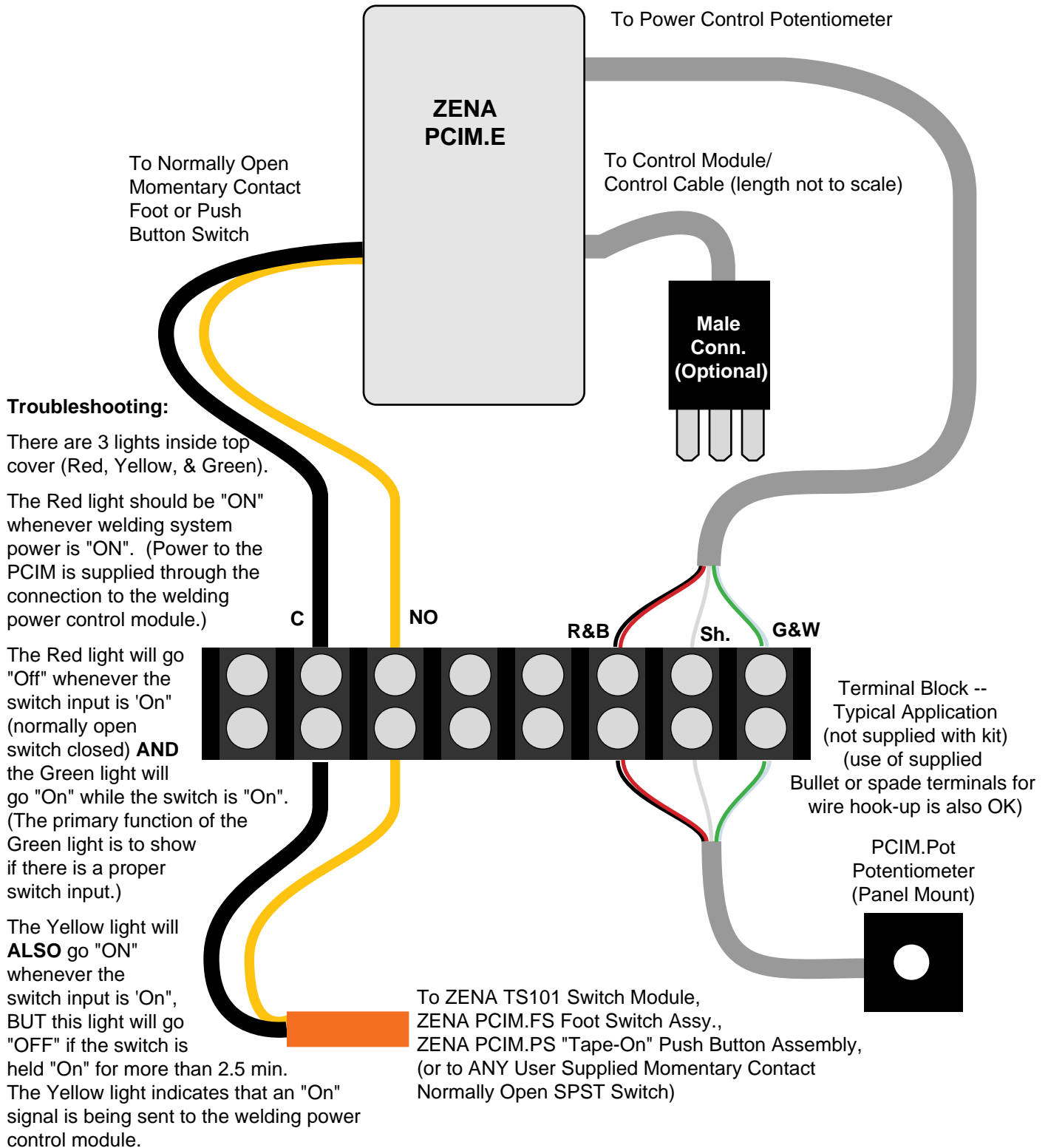



## ZENA TS101 Electrode Contact Sensor Switch -- Typical Hookup

